

MEGO (PPS-1024)

4-24V Portable Power Supply

1 Features

MEGO is a miniature power supply which can feed electrical power for low wattage circuits and electronics. MEGO generates wide output DC voltage from 4V to 24V with maximum output power of 6 Watts. The device is also designed to fit the standard 840 holes breadboards, so you are no longer bothered with the wiring headaches to power your circuit. The embedded 2000mAh rechargeable lithium polymer battery makes it truly convenient for applications that require portable and immediate power.

2 Functions

The basic components and their functions are illustrated by the following figures.

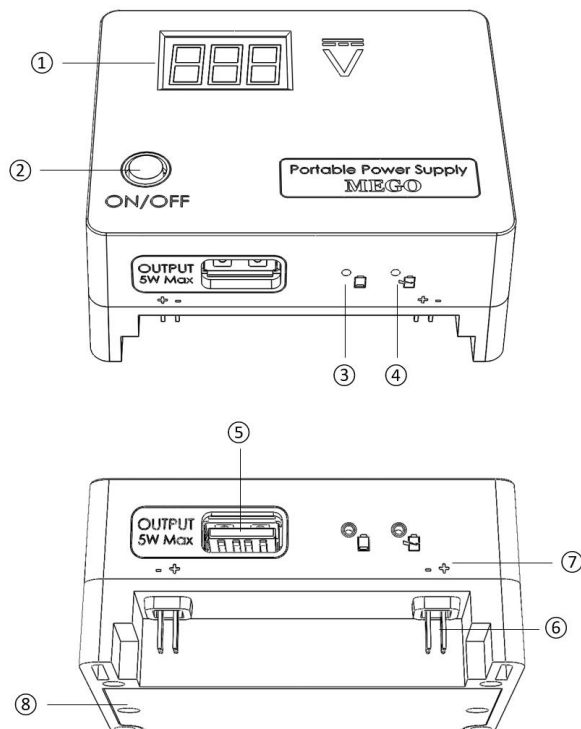
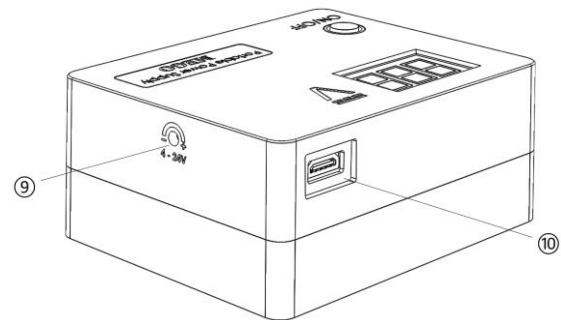

- ① Output voltage display
- ② Power push button
- ③ Low battery indicator (amber light)
- ④ Running/charging indicator (blue light)
- ⑤ Output USB connector (has same voltage as ①)
- ⑥ Breadboard power rail connection pins
- ⑦ Voltage polarity of ⑥
- ⑧ Battery lid
- ⑨ Output voltage adjusting knob
- ⑩ Input Micro USB connector for charging the device

We strongly recommend users to set the output voltage to 5V or less once you finished doing projects with MEGO.

3 Specifications

Dimensions

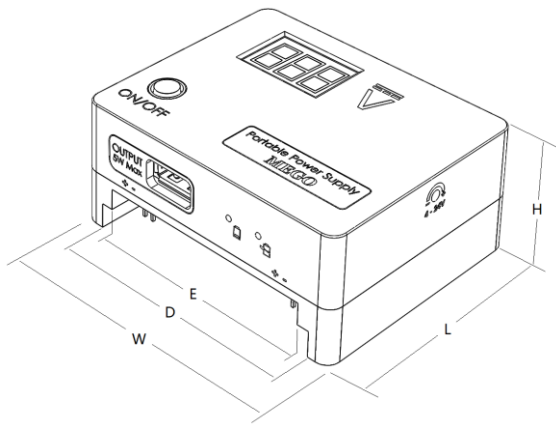

Parameter	mm(inches)
W	73(2.87)
L	59(2.32)
H	32(1.25)
D	62(2.44)
E	56(2.20)

Gross weight: 100g (3.5oz)

Electrical Specifications

Output Voltage	4-24VDC
Maximum Power	6W
Overload Protection	Yes
Short Circuit Protection	Yes
Battery Capacity	7.4Whs
Typical Power Efficiency ¹	88%
Voltage Display Accuracy	<1%
Ripple Voltage ²	<1%
Load Regulation ³	70mV
Operating Temperature	-15 to 45 °C
Storage Temperature	-20 to 50 °C

1. Calculated at $V_{OUT} = 5V$

2. Measured under $V_{OUT}=5V, 9V, 12V$

3. Measured at $V_{OUT}=5V, I_{OUT}$ from 10mA to 1000mA

Battery capacity

The battery capacity of MEGO is 7.4Whs, or 2000mAh at 3.7V. As a power supply, giving watt-hours allows you to quickly approximate the duration of operation using simple equation.

For example, using MEGO to drive a DC motor rated as 400mA @ 7V:

Step1: The power consumption of the DC motor is:

$$P_{\text{motor}} = 7V * 0.4A = 2.8W$$

Step2: Assuming 100% of efficiency, a fully charged MEGO can technically last for:

$$\text{Time}_{\text{ideal}} = \frac{7.4\text{Whs}}{2.8W} = 2.6\text{Hrs}$$

Step3: Count in the factor of efficiency, assuming 80%, then the approximated lasting time is:

$$\text{Time}_{\text{approx}} = 2.6\text{Hrs} * 0.8 = 2.2\text{Hrs}$$

But in practice, the device will most likely shut down before 2.2 hours simply because the battery voltage level is below the minimum threshold for the internal DC-DC converter, so some extra safety margin should be given if your application is very strict on the continuous running time.

4 Instructions

Turn ON/OFF the device

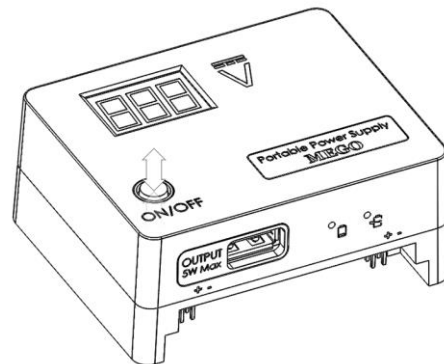

Charge the device

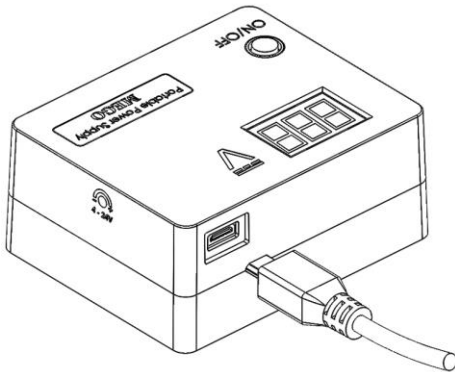

Use with a breadboard

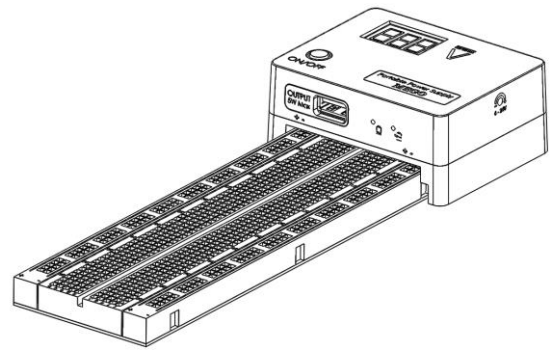

Adjust output voltage

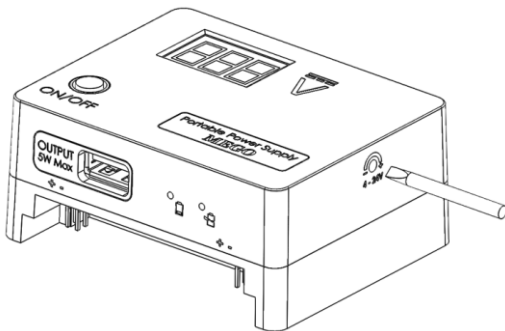

Power non-breadboard circuits

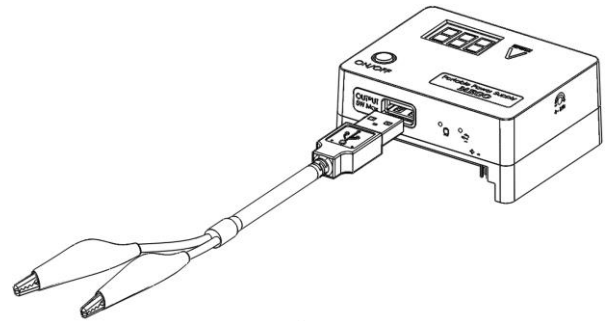

Meaning of the LED Indicators

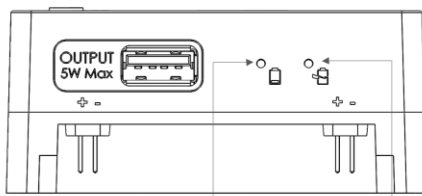

Low battery indicator: amber light turns on when MEGO is in low battery condition.

Running indicator: blue light turns on while MEGO is operating, or the device is being charged

Charging smartphones

In urgent situations where you have a low battery cellphone but do not have access to wall plug, you can use MEGO as a power bank. The USB output port on MEGO was designed to be compatible for charging most types of smartphones. **Be sure to set the output voltage to 5V or less before you charge the phone.** The charging current was restricted at 500mA so it will be slower than using a wall adapter.

5 Advanced Applications

Here are some example applications that require two MEGOs.

Powering Dual Rail Op-amps

Some integrated circuits such as Opamps may require dual voltage supply for powering up, which means that you need to have both positive and negative voltage. A dual voltage supply setup can be achieved with two MEGOs by using the setup as shown below.

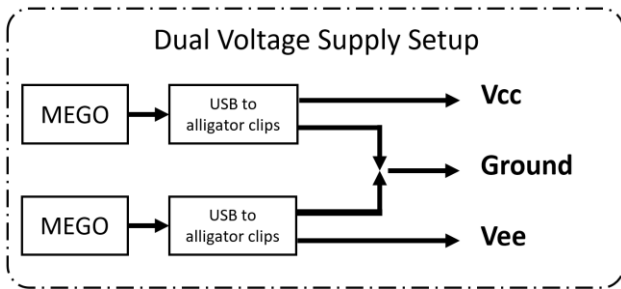

Larger Output Current

Some devices require higher electrical power while operating, such as DC motors, LED arrays, transmitters, speakers... Since each MEGO is recommended to operate under 5W, if you want to drive electronics with higher power consumption, a simple way is to set multiple MEGOs in parallel mode as shown below, to enhance current supply capability.

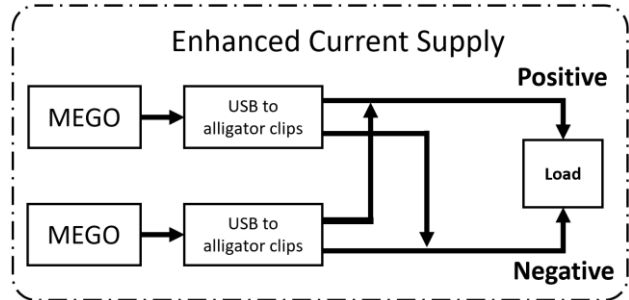

Measure DC Voltage

MEGO can be also used to measure DC voltage. Before you do that, keep in mind that MEGO CANNOT source and measure simultaneously. You can measure a DC voltage (**within 3-30V range**) using the USB to alligator clip, but make sure you TURN OFF the device first.

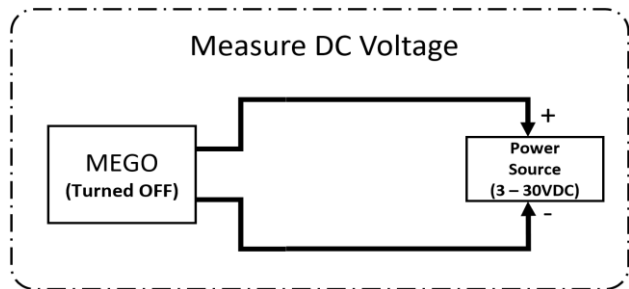

Contact

Website: www.eimtechnology.com

Email (general): info@eimtechnology.com

Email (technical): service@eimtechnology.com

Address: 180-6660 Graybar Rd, Richmond, BC